

NOTES:

1. FOR GRAVITY APPLICATIONS ONLY.
2. ALL PROCEPTOR® UNITS ARE MANUFACTURED WITH FIBERGLASS REINFORCED PLASTICS. PHYSICAL CHARACTERISTICS AND THICKNESS: POLYESTER RESIN AND E GLASS. MINIMUM THICKNESS 1/4" WALL AND 3/8" TOP AND BOTTOM BOWLS.
3. ALL PROCEPTOR® UNITS ARE TO BE INSTALLED IN ACCORDANCE WITH THE MANUFACTURERS INSTALLATION INSTRUCTION.
4. STANDARD PIPE STUBS ARE SOCKET SDR 35 PVC SEWER MATERIAL (SCHEDULE 40 ADAPTORS ADDED FOR ALL PROJECTS IN USA).
5. GMC/OMC/SMC 50 - 300 UNITS COME STANDARD WITH 4" INLET AND OUTLET (OTHER CUSTOM SIZES AVAILABLE AT EXTRA CHARGE).
6. EXTENSION COLLAR TO BE ORDERED TO MEET FINISHED GRADE, CUT ON SITE FOR FINAL ADJUSTMENT AND CAULKED WITH SIKAFLEX BY CONTRACTOR FOR WATERTIGHT SEAL.
7. COVERS AVAILABLE FOR H2O TRAFFIC LOADING. PEDESTRIAN LOADING OR ABOVE GROUND INSTALLATION.
8. CONSULT GREEN TURTLE™ FOR OTHER SIZES.
9. 30 YEAR WARRANTY AGAINST LEAKS, AND STRUCTURAL FAILURE.
10. U.S. PATENT #5,746,912; CDN PATENT #2,195,822

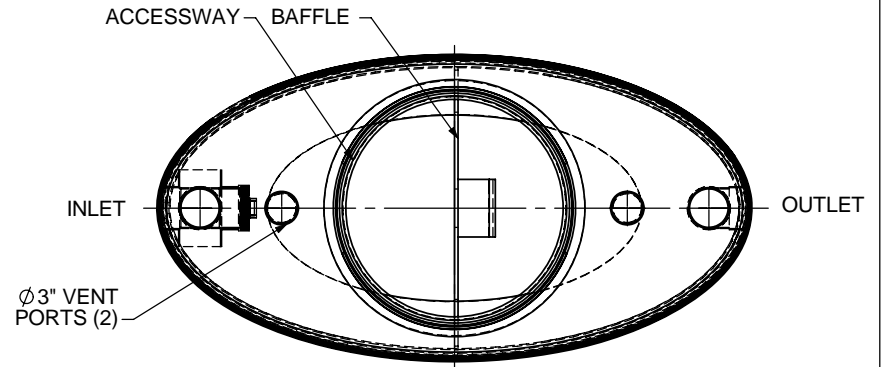

TOP VIEW

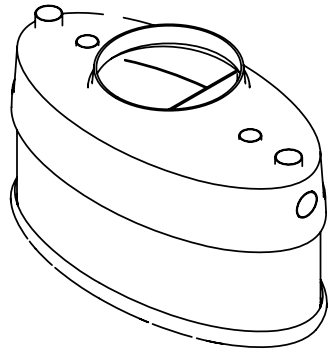

ISOMETRIC VIEW

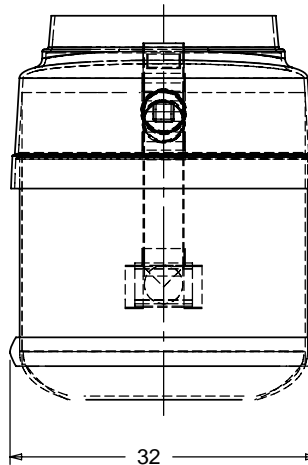

SIDE VIEW

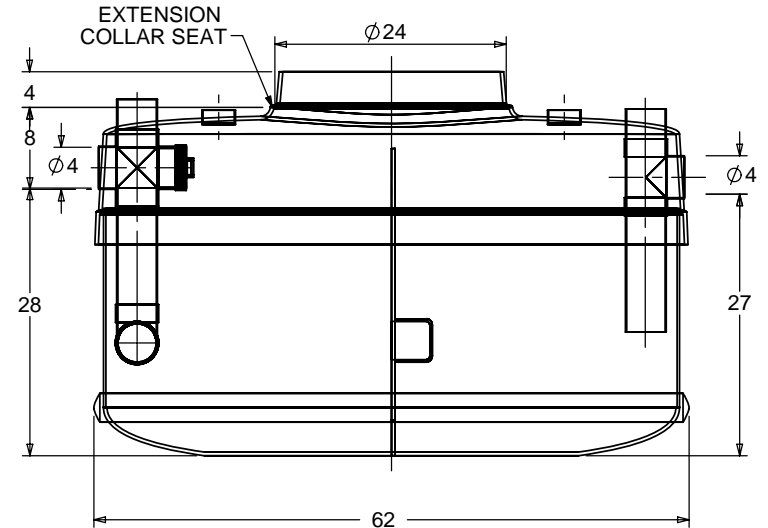

FRONT VIEW

TOTAL WET VOLUME: 150 GAL
 MAX. GREASE CAPACITY: 66 GAL
 MAX SOLIDS CAPACITY: 48 GAL

CONSULT LOCAL AUTHORITIES FOR MINIMUM SIZE OF SEPARATORS

TITLE: PROCEPTOR® F.O.G. SEPARATOR
 GMC 150 GALLON INTERCEPTOR
 4" INLET & OUTLET
 24" ACCESSWAY
 ALL DIMENSIONS IN INCHES

PROJECT: WO:

- OPTIONS:
- GREASE SENSOR ALARM
 - SUCTION PIPE FOR INDOOR INSTALLATION
 - ABOVE GROUND INSTALLATION

REV	DATE	DRAWN
1		
2		
3	JUNE 1, 2005	L. SIMKINS
4	OCTOBER 27, 2006	L. SIMKINS
5	DEC. 13, 2006	L. SIMKINS
6	JUNE 18, 2007	L. SIMKINS
7	JUNE 20, 2007	L. SIMKINS
8	NOVEMBER 24, 2008	L. SIMKINS
9	NOVEMBER 3, 2009	L. SIMKINS
10		

DRAWN BY: F CHANDLER
 DRAWN DATE 9/2/04

Proceptor®
 by greenturtle®
 US 877 428 8187 CAN 877 966 9444
 www.greenturtletech.com

SIZE	DWG. NO.	REV.
A	GMC 150	9
SCALE: 1:20	DO NOT SCALE DRAWING	SHEET 1 OF 1