

NOTES:

1. FOR GRAVITY APPLICATIONS ONLY.
2. ALL PROCEPTOR UNITS ARE MANUFACTURED WITH FIBERGLASS REINFORCED PLASTICS. PHYSICAL CHARACTERISTICS AND THICKNESS: POLYESTER RESIN AND E GLASS. MINIMUM THICKNESS 1/4" WALL AND 3/8" TOP AND BOTTOM BOWLS.
3. ALL PROCEPTOR UNITS ARE TO BE INSTALLED IN ACCORDANCE WITH THE MANUFACTURERS INSTALLATION INSTRUCTION.
4. STANDARD PIPE STUBS ARE SOCKET SDR 35 PVC SEWER MATERIAL (SCHEDULE 40 ADAPTORS ADDED FOR ALL PROJECTS IN USA).
5. GMC/OMC 500 - 3000 UNITS COME STANDARD WITH 6" INLET AND OUTLET (OTHER CUSTOM SIZES AVAILABLE AT EXTRA CHARGE).
6. EXTENSION COLLAR TO BE ORDERED TO MEET FINISHED GRADE, CUT ON SITE FOR FINAL ADJUSTMENT AND CAULKED WITH SIKAFLEX BY CONTRACTOR FOR WATERTIGHT SEAL.
7. COVERS AVAILABLE FOR H2O TRAFFIC LOADING, PEDESTRIAN LOADING OR ABOVE GROUND INSTALLATION.
8. CONSULT GREEN TURTLE FOR OTHER SIZES.
9. 30 YEAR WARRANTY AGAINST LEAKS, AND STRUCTURAL FAILURE.
10. U.S. PATENT #5,746,912; CDN PATENT #2,195,822

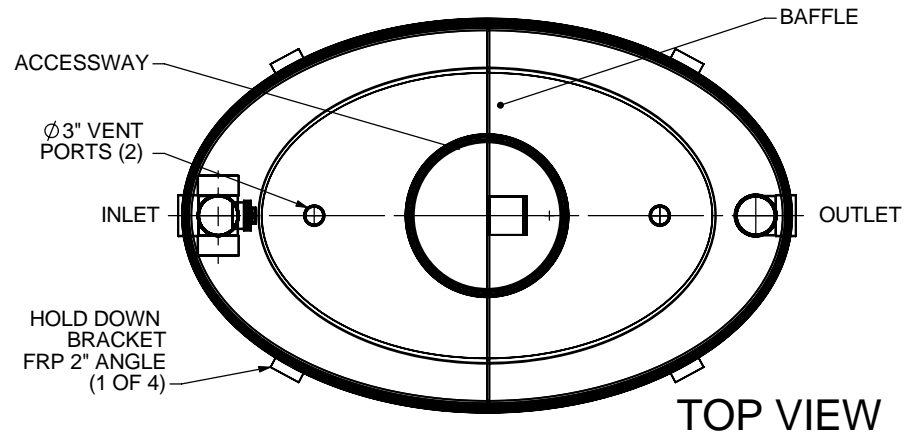

TOP VIEW

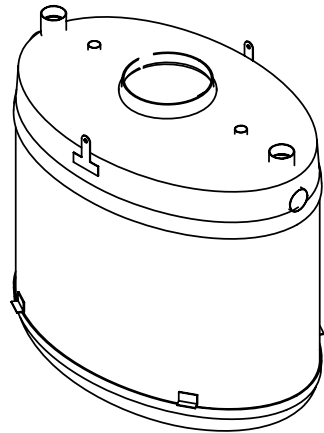

ISOMETRIC VIEW

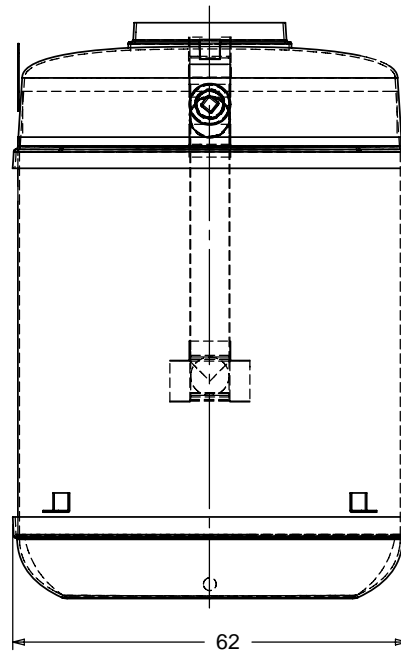

SIDE VIEW

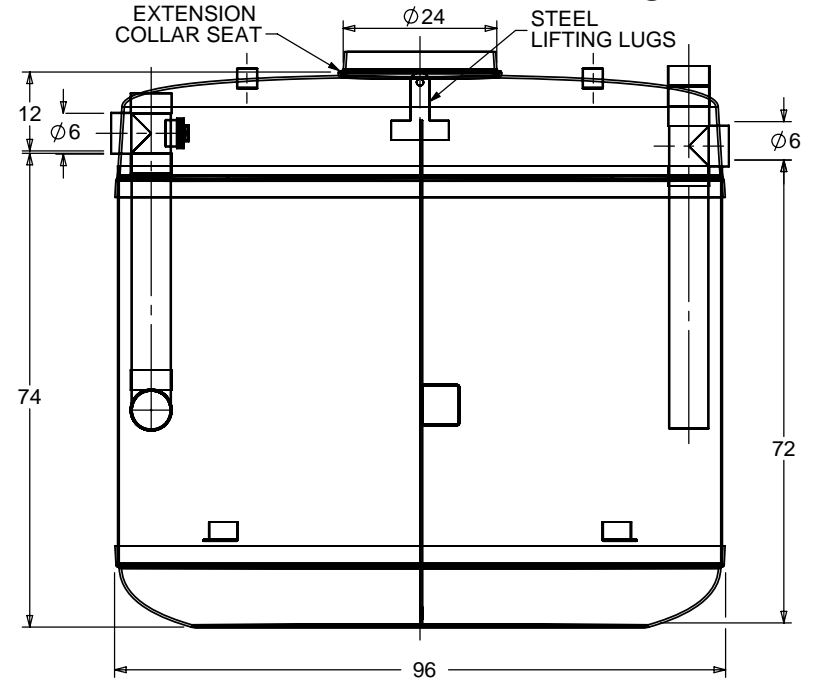

FRONT VIEW

TOTAL WET VOLUME: 1300 GAL
 MAX. OIL CAPACITY: 707 GAL
 MAX SOLIDS CAPACITY: 446 GAL

CONSULT LOCAL AUTHORITIES FOR MINIMUM SIZE OF SEPARATORS

TITLE: PROCEPTOR OIL SEPARATOR
 OMC 1300 GALLON INTERCEPTOR
 6" INLET & OUTLET
 24" ACCESSWAY
 ALL DIMENSIONS IN INCHES

PROJECT: WO:

- OPTIONS:
- OIL SENSOR ALARM
- COALESCER FOR OIL REMOVAL
- ABOVE GROUND CONFIGURATION
- SUCTION PIPE FOR INDOOR INSTALLATION
- DOUBLE WALL CONSTRUCTION

REV	DATE	DRAWN
1		
2		
3	JUNE 15, 2005	L. SIMKINS
4	JANUARY 4, 2007	L. SIMKINS
5	NOVEMBER 11, 2009	L. SIMKINS
6		
7		
8		
9		
10		

DRAWN BY: F. CHANDLER
 DRAWN DATE 9/14/04

Proceptor[®]
 by **greenturtle**[®]
 US 877 428 8187 CAN 877 966 9444
 www.greenturtletech.com

SIZE	DWG. NO.	REV.
A	OMC 1300	5
SCALE:1:30		SHEET 1 OF 1