

- NOTES:**
- FOR 2 x 62" X 96" ELLIPSE TANKS
 - NO. 4 REBAR (ϕ 1/2") CONNECTED WITH TIE WIRE
 - REBAR TO BE 2.5" FROM FACE OF CONCRETE
 - REBAR SPACING 12" GRID, 4" SPACING AROUND ACCESS OPENINGS
 - MINIMUM 36" FROM TOP OF SLAB TO TOP OF TANK
 - CAST SLAB AROUND COLLAR AND FRAME

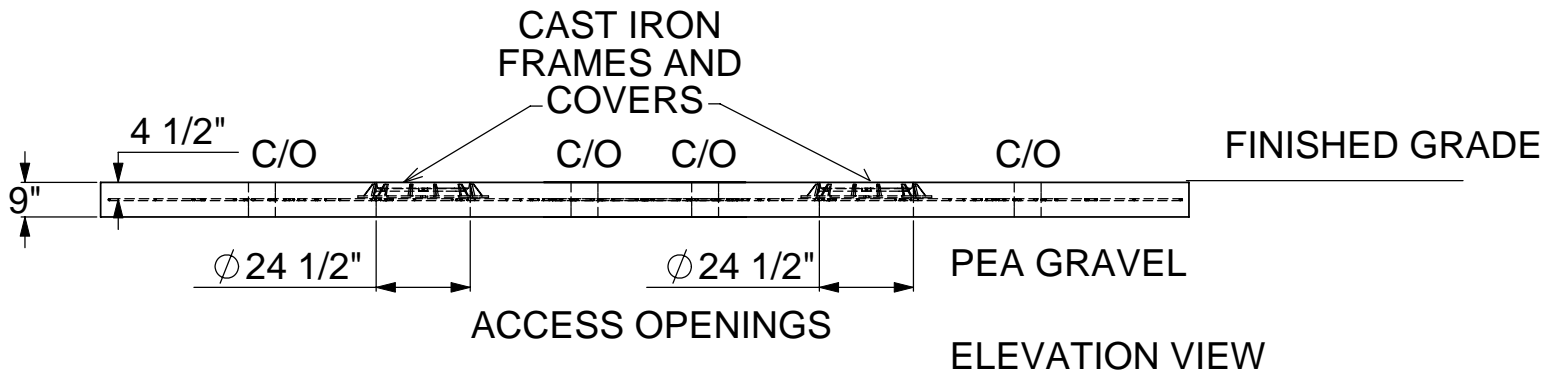

TITLE: H2O TRAFFIC LOADING SLAB FOR DUAL ELLIPTICAL TANK ALL DIMENSIONS ARE IN INCHES UNLESS OTHERWISE SHOWN.		REV	DATE	DRAWN	<p style="text-align: right;">TM</p> <h1 style="margin: 0;">greenturtle</h1> <p style="margin: 0;">877 428 8187 US 877 966 9444 CAN www.greenturtletech.com</p>	
PROJECT: WO:		1				
✓ CONFIGURATION:		2				
		3				
		4				
		5				
		6				
		7				
		8				
		9				
		10				
		DRAWN BY: L. SIMKINS		SIZE	DWG. NO.	REV.
		DRAWN DATE: AUGUST 28, 2008		A	DOUBLE SLAB	
		SCALE: 1:50		DO NOT SCALE DRAWING		SHEET 1 OF 1